



# Catálogo de Productos

## Products Catalog



La Evolución del Packaging  
Packaging Evolution



Ruta Prov. N° 6  
Km 36,6 (S3013ZAA)  
San Carlos Centro  
Prov. de Santa Fe Argentina  
Tel./Fax.: (54 3404) 420129  
bisig@bisignano.com.ar  
[www.bisignano.com](http://www.bisignano.com)



Línea Packaging  
Packaging Line

## Ingeniería y Automación

Engineering and Automation

La ingeniería es nuestro punto estratégico, caracterizada por el alto nivel tecnológico y la capacidad de respuesta ante los nuevos retos. Un sector maduro, con alto grado de especialización y cualificación técnica.

Engineering is our strategic point, characterized by the high technological level and the ability to respond to new challenges. A mature sector, with a high degree of specialization and technical qualification.

Nuestra apuesta por la innovación y el desarrollo tecnológico nos brinda la posibilidad de aplicar sistemas integrados de control de operaciones, logrando la completa automatización de los procesos productivos.

Our commitment to innovation and technological development gives us the possibility of applying integrated operation control systems, achieving complete automation of production processes.

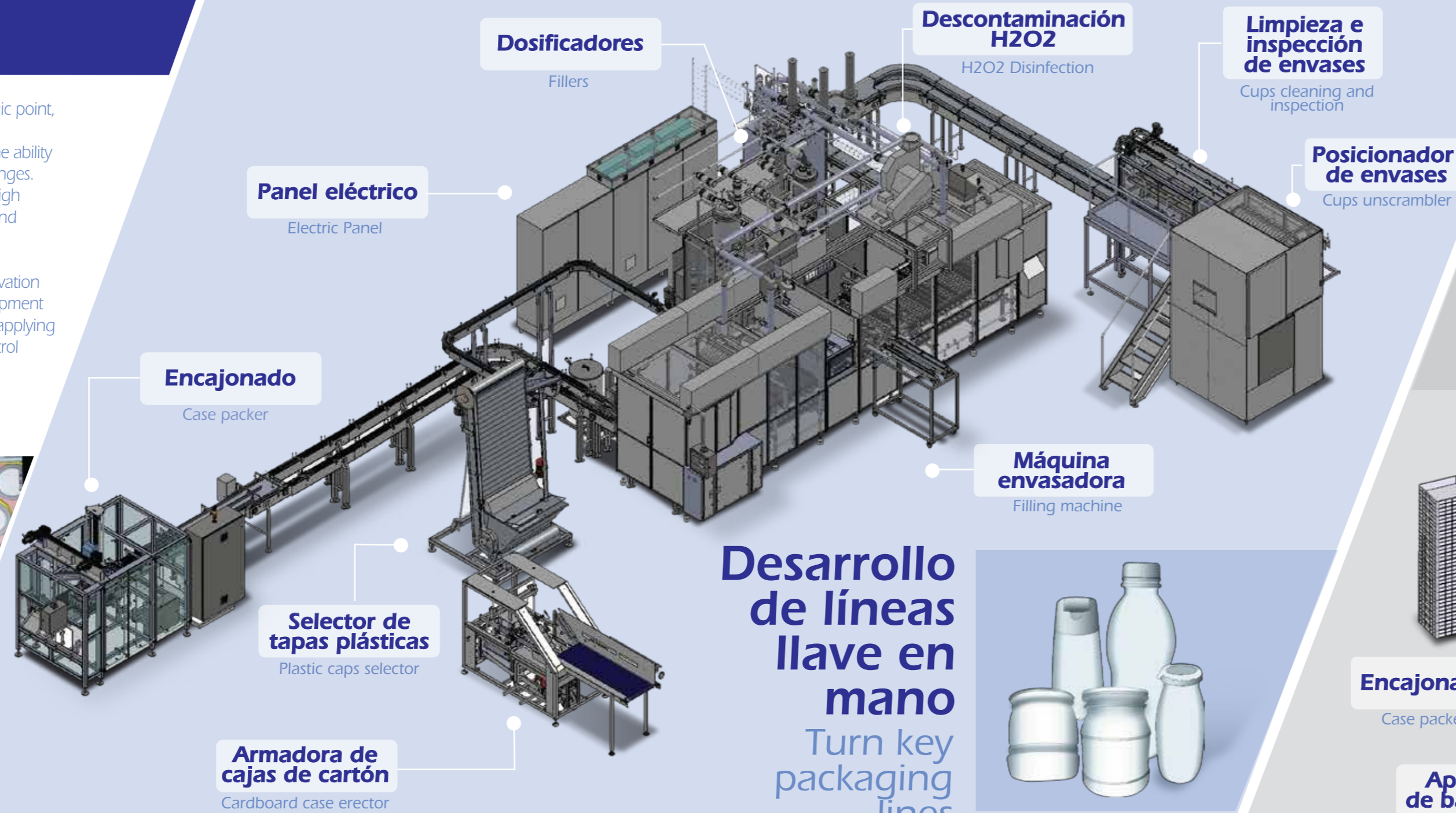

## Desarrollo de líneas llave en mano

Turn key packaging lines



## Soluciones a medida

Tailored Solutions

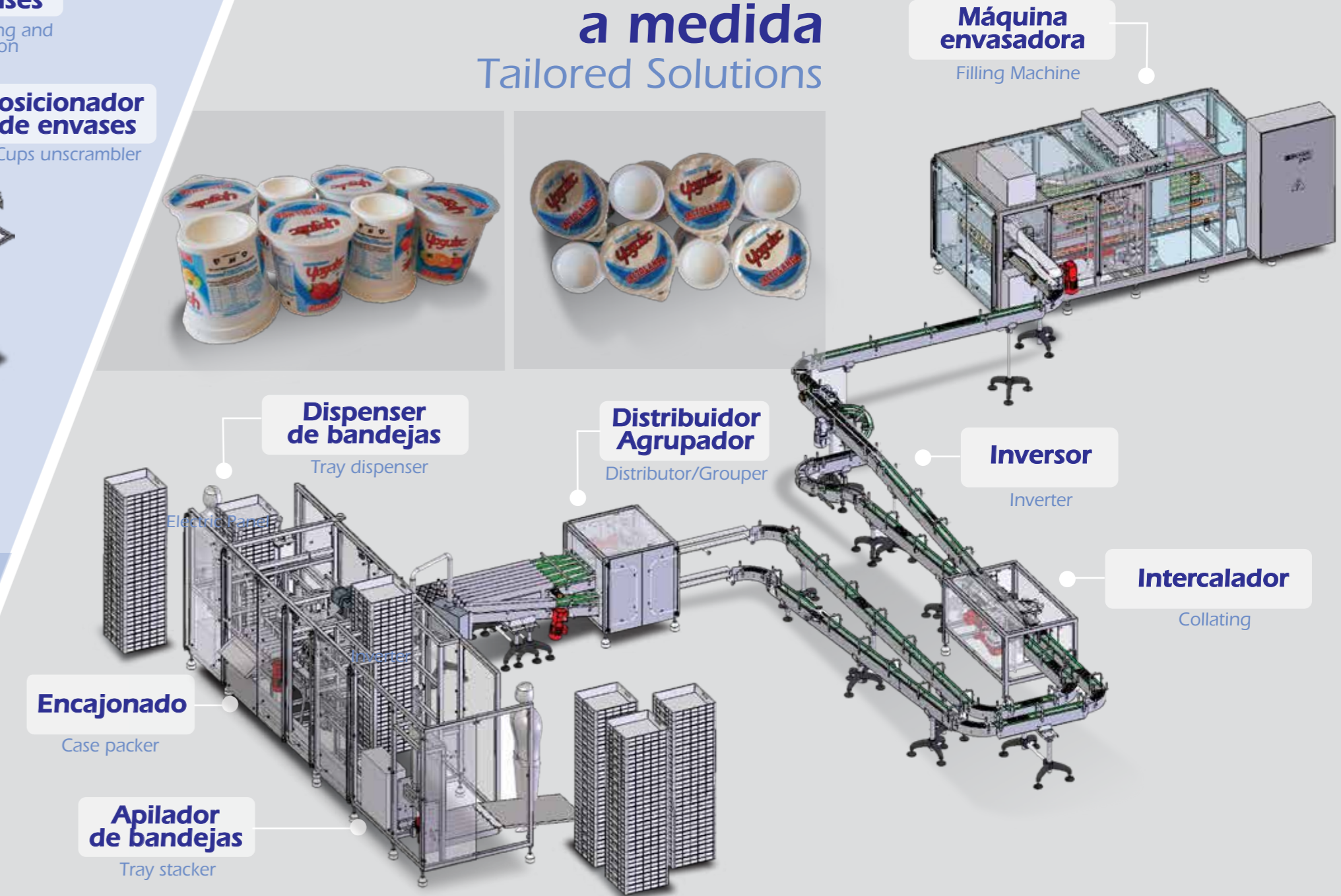



## Política de calidad

### MISSION

Lograr que nuestros clientes se posicionen en el mejor nivel tecnológico con calidad y servicio de excelencia.

### VISION

Ser una empresa líder a nivel internacional, referente en el rubro, capaz de adaptarse exitosamente a la dinámica del mercado global, obteniendo un nivel de rentabilidad que permita el crecimiento sostenido.

### VALORES

Trabajo en equipo.  
Honestidad e integridad.  
Excelencia con mejora continua.

## Our Policy

### MISSION

Favor our customers to reach the highest technological level, with excellence in quality and service.

### VISION

To be a leading company at international level, capable of a quick successful adaptation to the dynamics of the global market.

### VALUES

Team work.  
Honesty and Integrity.  
Excellence in Continuous Improvement.

## Planta Industrial

Industrial Plant



## Información Institucional

Bisignano tiene sus orígenes en 1952 y hoy con más de 60 años de trayectoria, tiene un perfil global y se encuentra en permanente expansión. Sus equipos se hallan instalados en las firmas más exitosas y prestigiosas del mundo. La empresa se especializa en el diseño, fabricación y servicio de equipos para el proceso y envasado de alimentos. En la búsqueda de soluciones únicas a la medida de las necesidades de sus clientes se halla el perfecto equilibrio entre la concepción de las ideas y su realización material. Basados en lineamientos de calidad y confiabilidad, invertimos en capacitación del personal, participación en ferias de todo el mundo, permitiendo una actualización constante en materia tecnológica.

Como consecuencia de ello y de un fuerte compromiso con los clientes, Bisignano ha logrado alcanzar el primer nivel internacional transformándose en la empresa que fabrica máquinas envasadoras de alimentos con mayor éxito en Latinoamérica. En mención a estos logros alcanzados, ha cosechado innumerables premios y reconocimientos Nacionales e Internacionales, posicionándose como un referente de primer nivel mundial.

## Institutional Information

Bisignano was born in 1952, and nowadays, with more than 60 years of existence, it has developed a global profile and is in constant expansion. Our equipment are installed in the most famous and successful companies all over the world. The company specializes in the design, manufacturing and service of equipment for food processing and packaging. The perfect balance between conception of ideas and their materialization is in the search of unique solutions for our customer's needs. To enhance quality and reliability, we invest in training and education of the personnel and take part in international packaging trade fairs to be updated in state-of-the-art technology. As a result of this approach and a strong commitment with our

customers, Bisignano has achieved international recognition, becoming the most successful Latin-american company that manufactures packaging machinery. We have been granted several awards, both National and International, which place the company at first level

## Máquinas Envasadoras Rotativas

Rotary Cups Filling Machines

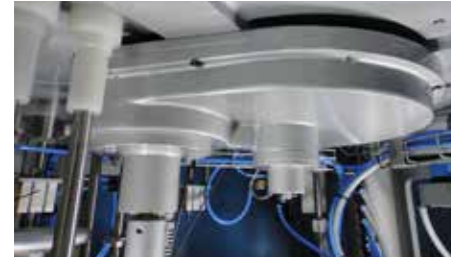

Alto rendimiento - Fácil operación  
High performance - Easy operation



Rápido cambio de formato  
Quick change of format



Cámara de aire filtrado  
Filtered air chamber



**Rc**

Hasta 4.000 envases / hora  
Up to 4.000 cups / hour



- Opción Ultra Clean
- Cerramiento de seguridad
- Cámara de aire filtrado
- Ultra Clean Option
- Safety closing
- Filtered air chamber

**Rg**

Hasta 10.000 envases / hora  
Up to 10.000 cups / hour



## Máquinas Envasadoras Lineales

Linear Cups Filling Machines

**DLB<sub>c</sub>**

Hasta 12.000 envases / hora  
Up to 12.000 cups / hour



- Eficiencia 98%
- Bajo mantenimiento
- Efficiency 98%
- Low maintenance

Encajonador incorporado  
Integrated case packer



Bajo nivel sonoro  
Low sound level



Operación a nivel de piso  
Floor level operation



**DLB<sub>g</sub>**

Hasta 18.000 envases/hora  
Up to 18.000 cups / hour



## SIGNA cups

Motorcord

Hasta 45.000 envases por hora  
Up to 45.000 cups/hour



Sistema con acceso externo  
para carga de tapas  
External Lids Loading Device



Cabezales dosificadores para productos  
líquidos y/o viscosos  
Filling heads for liquid and/or  
viscous products



Colocador de tapas con sistema  
de desinfección UV  
Lids dispenser with UV  
disinfection system

## Máquinas envasadoras para botellas y frascos

Filling machines for bottles and jars



### Contifill

Hasta 15.000 envases/hora.  
Up to 15.000 cups/hour.



Dosificador servoactuado  
Servodriven Filler



Troqueladora de tapas  
Lids cutter



Tapa de aluminio y termosellado  
Aluminium lids and heatsealer

### Para productos larga vida

For long shelf-life products

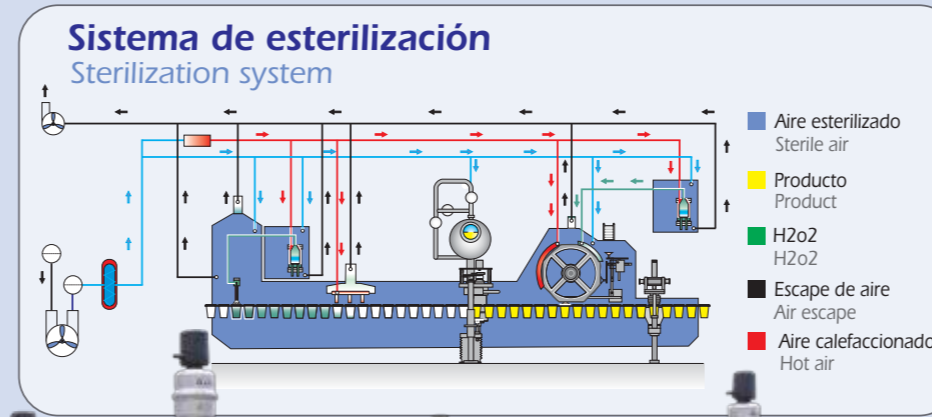

### SIGNA aseptic

Hasta 40.000 envases/hora.  
Up to 40.000 cups/hour.

## Línea de envasado de sobrecopas

Overcups filler



Dosificador de cereal  
Cereal Filler



Colocador de cucharitas  
Spoons Dispensing



**Soluciones integrales**  
Integral solutions



**de principio a fin.**  
from beginning to end.



**Envasadoras Termoformadoras (ffs)**  
Form Fill Seal Machines

**SIGNA ffs**

Motorcord

Hasta 40.000 envases/hora.  
Up to 40.000 cups/hour.



Con o sin Decor  
With or without Decor

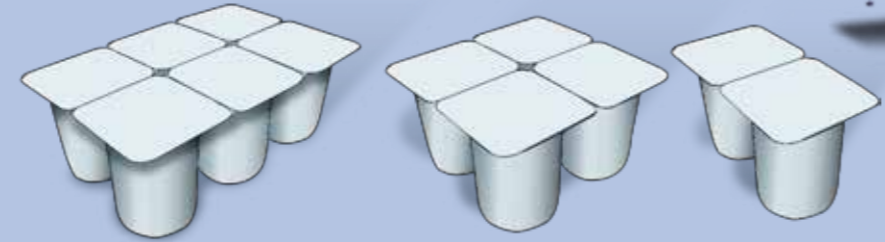

**ffs mini**

Hasta 36.000 envases/hora.  
Up to 36.000 cups/hour.



**ffs due**

Hasta 20.000 envases/hora.  
Up to 20.000 cups/hour.



**DISEÑO EXCLUSIVO**  
EXCLUSIVE DESIGN

En la evolución del packaging, Bisignano ha desarrollado este sistema. Se trata de la combinación de dos tamaños de decor, que otorga al envase resistencia mecánica en sus paredes laterales; logrando además un impacto visual novedoso y positivo.

In the evolution of the packaging, Bisignano has developed an exclusive cup. It is the combination of two sizes of decor that gives strength to cup's walls. A novel and positive visual impact is achieved.



Encajonado automático mediante robot  
Automatic case packer with robot



Aplicador Decor  
Decor Labelling



Dosificadores para productos líquidos y/o viscosos  
Filling heads for liquid and/or viscous products



Pre Calentador - Formador  
Pre-Heating - Forming Stations



Dosificador  
Filler



Encajonador automático  
Automatic Case Packer



Cabezal guía doble decor  
Double Decor guiding head



Área de formado y decorado  
Thermoforming and decoration area





# ffs flex

**Hasta 20.000 envases/hora.**  
Up to 20.000 cups/hour.

**Fácil cambio de formato con DOS alturas de Decor**

Easy Change Over with TWO Decor heights

Termoformadora totalmente automática completamente servoactuada. Cámara de flujo laminar y dosificador preparado para limpieza CIP. Para yogur, yogur con frutas y postres.

Ffs machine completely servodriven. Laminar flow chamber and filler prepared for CIP cleaning. Yoghurt - Yoghurt with fruits and desserts.



Decor 1

Decor 2

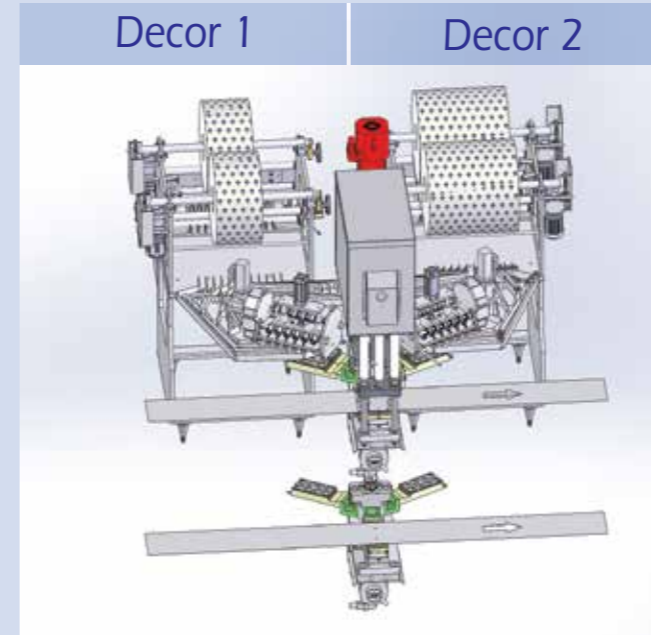

Aplicador de decor  
Decor labelling

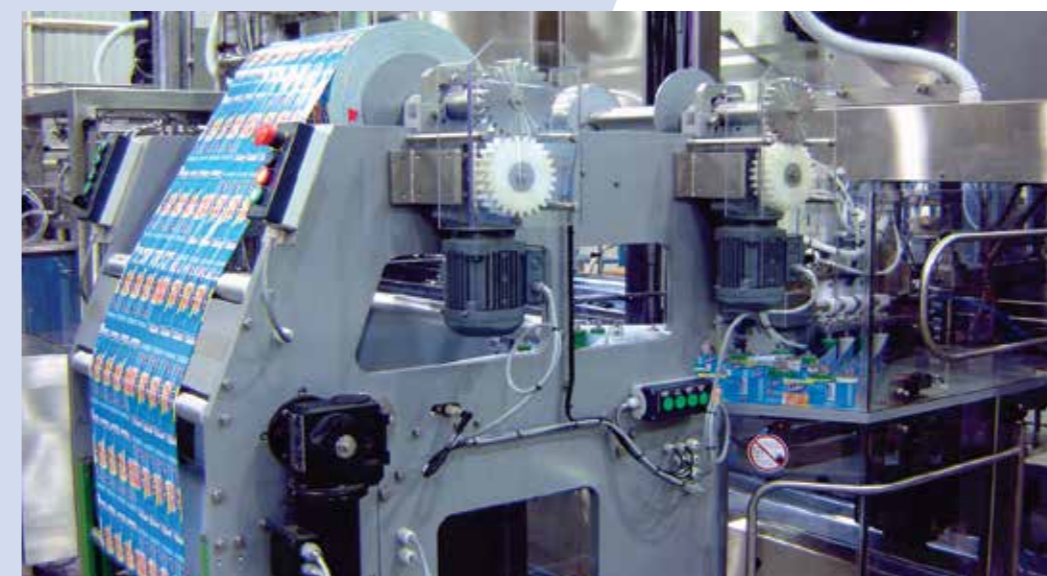

**Preparada para realizar diferentes presentaciones**

Prepared to make different presentations

**CON Y SIN DECOR**  
WITH OR WITHOUT DECOR

		Decor: 30 mm 60 g.	
		Decor: 30 mm 100 g.	
		Decor: 54 mm 120 g.	
		Decor: 54 mm 150 g.	
		Decor: NO 90 g.	
		Decor: NO 100 g.	

**NUEVO PRODUCTO**  
NEW PRODUCT



Para mas información sobre nuestros productos y servicios visite nuestro sitio web.  
For more information about our products and services visit our web site.

[www.bisignano.com](http://www.bisignano.com)



Certificación ISO 9001:2008  
Diseño, fabricación y servicio post-venta de equipos para proceso y envasado de alimentos.